

COLOR: WHITE

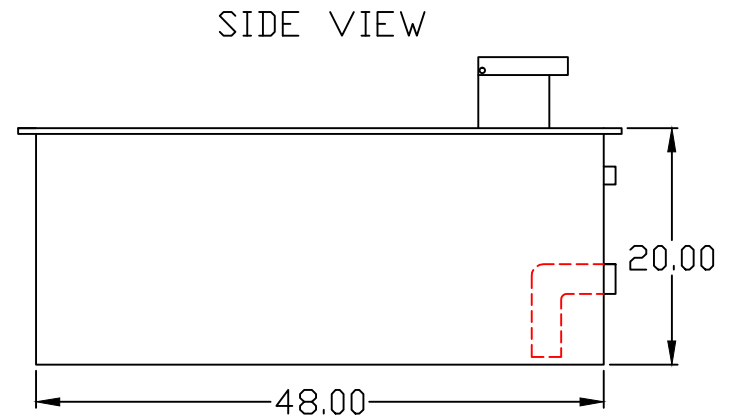
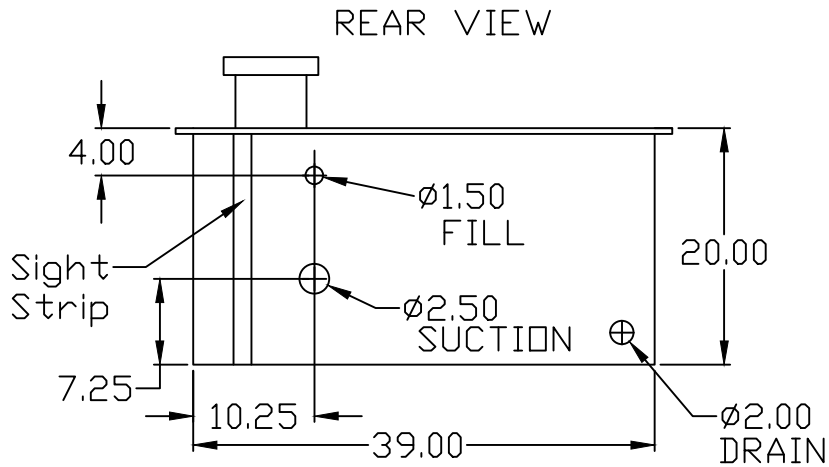
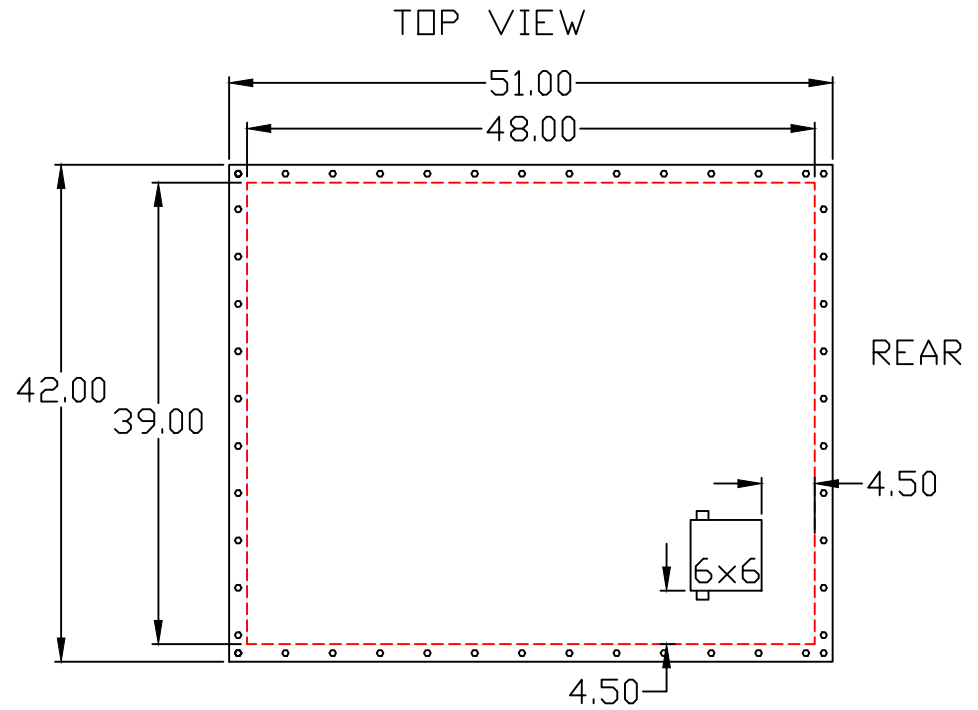

CUSTOM COMPOSITES
1018 E. Madison Street
Oklahoma City, OK 73111
1-877-912-6297
Phone: 405-424-2550
Fax: 405-424-2556
www.CustomCompositesOK.com

Customer's Signature and Date

Title

150 GALLON FIBERGLASS TANK (ECONOMY)

Customer

Foam Capacity
0 GALLONS

Material
FIBERGLASS

Water Capacity
150 GALLONS

TYPE:
ECONOMY TANK