

NOTES:
 FOAM CELL TO INCLUDE VENT &
 LATCH

OVERFLOW EXITS OUT PASSENGER
 SIDE OF TANK AND IS FLUSH
 WITH OUTSIDE OF TANK

TOP VIEW

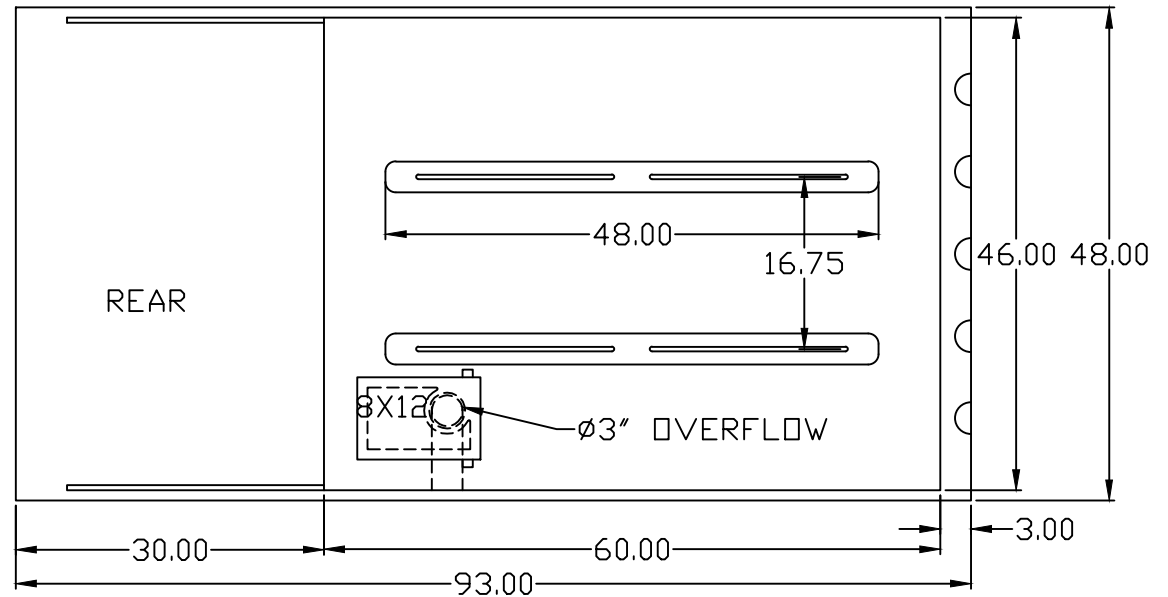

REAR VIEW

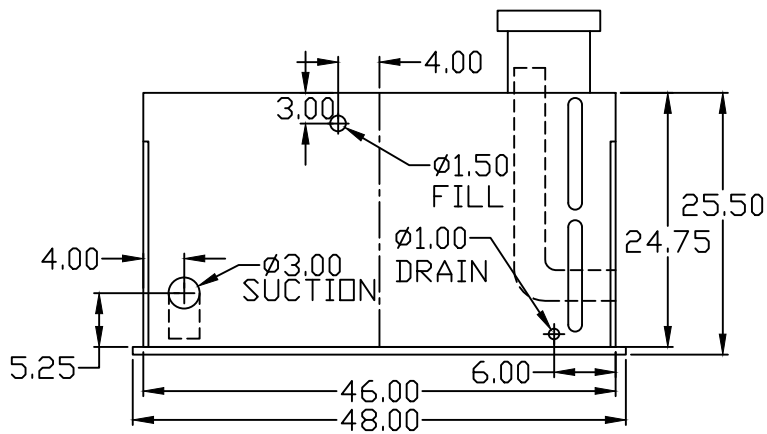

SIDE VIEW

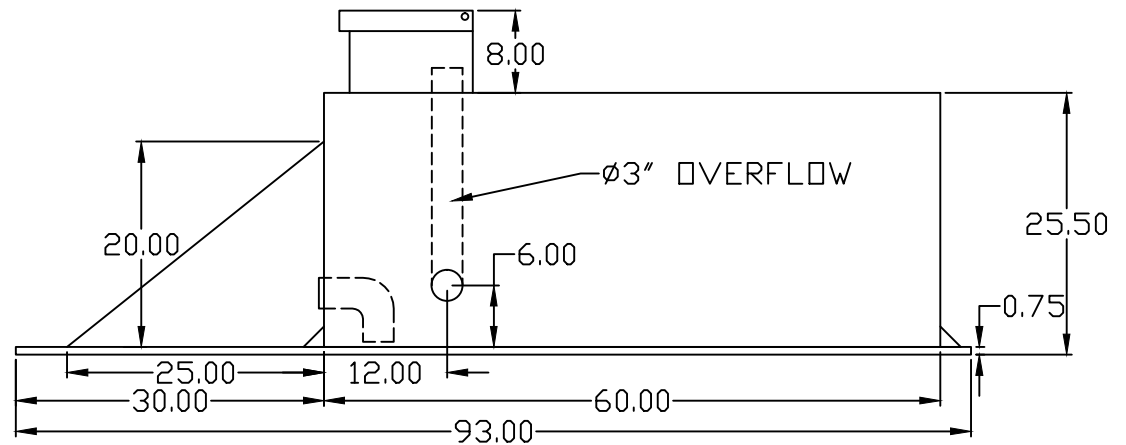

CUSTOM COMPOSITES
 1018 E. Madison Street
 Oklahoma City, OK 73111
 1-877-912-6297
 Phone: 405-424-2550
 Fax: 405-424-2556
 www.CustomCompositesOK.com

Customer's Signature and Date

Title 250 GALLON POLYPROPYLENE TANK (ECONOMY)		
Customer	Foam Capacity 0 GALLONS	Material POLYPROPYLENE
	Water Capacity 250 GALLONS	TYPE: ECONOMY TANK